

PCM Ignition Output
*see note 3

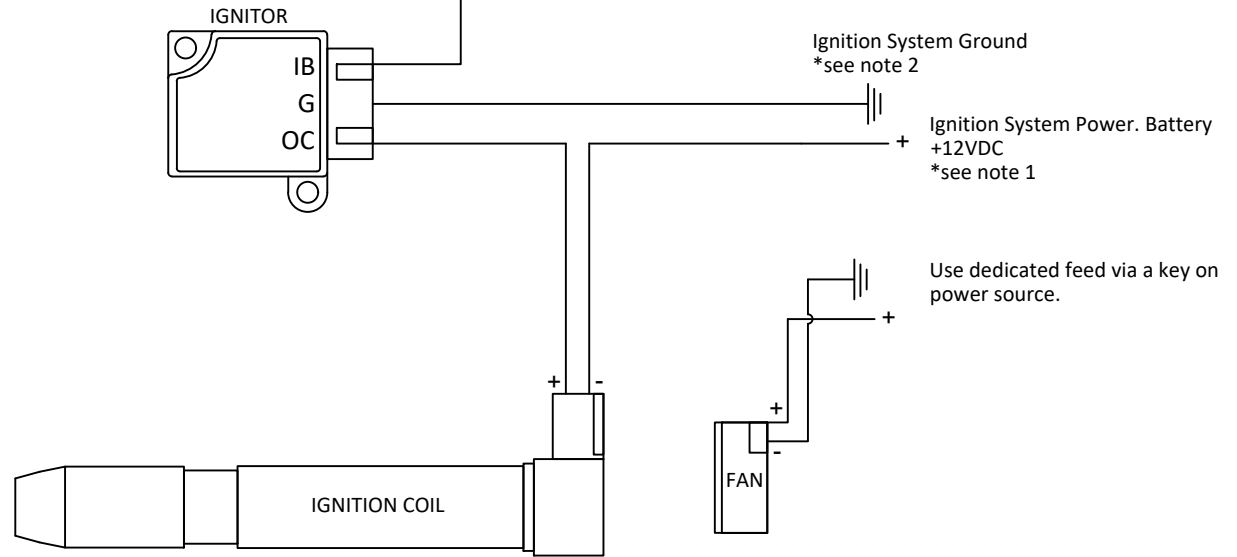
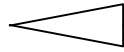

NOTE 1 - Connect to battery post or alternator power cable.
Wire in 40 amp relay to switch ignition energy on during keystart.

NOTE 2 - Use engine block or negative battery post for ground point. When grounding to engine be sure that heavy gauge wire is used to ground engine block to negative battery post.

NOTE 3 - Square Wave line Input required with voltage of 5 - 12 volts DC. Ignitor fires on falling edge trigger and charges based on duty cycle. If ECU TTL output is not 5V, please use WeaponX Intelligent signal conditioner.

NOTE 4 - Typical dwell time for Coil On Plug units is 1.8 and 3.2 for typical ignition coils.

**WEAPONX
IGNITOR
WIRING**

MISSION IGNITION SYSTEMS

Revision C - PN IMST11X